

PORTABLE SUBMERSIBLE DRAINAGE PUMP “2PDS&W” Series





PORTABLE SEWAGE / DRAINAGE PUMP (2PDSEW SERIES)

The "2PDSEW" Series is designed in single Stage Submersible centrifugal Portable Sewage/Drainage pump of closed coupled vertical(mono block type) construction , This series pump are available with various type of Impeller as per customer's application like Vortex , Channel, Single Vane depanded on soild size & application.

TECHINCAL DATA

HP /KW	:	0.5 HP TO 7.5 HP
RPM	:	2900/1440
HEAD RANGE	:	MAX. UP TO 40 MTR
DISCHARGE	:	MAX. UP TO 150 M3/HR
TYPE OF IMPELLER	:	SEMI OPEN/VORTEX/CHANNEL
MOTOR	:	"F" CLASS / S1 DUTY
SUPPLY	:	230 OR 415 VOLT /AC SUPPLY /50HZ
SOLID SIZE	:	UP TO 50 MM
CABLE	:	DOUBLE SHEATED, OIL & WATER
TEMPERATURE	:	PROOF MAX. UP TO 40 DEGREE

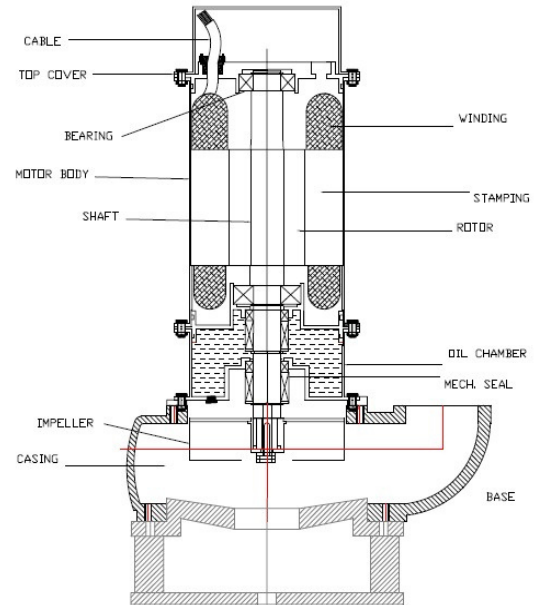

APPLICATION

MATERIAL OF CONSTRUCTION

# Construction Site	# Thermal Power	Motor Body	: S.S.
# Fire Fighting	# Steel Plant	Top Housing	: C.I./ S.S.
# Chemical Industires	# Municipal Corporation	Seal Housing	: C.I./S.S.
# Process Industires	# Rain Water	Rotor Shaft	: S.S. 410 OR S.S. 431
# ETP Plant	# Hotel/ Hospital	Impeller	: S.S. 410/S.S. 316 OR C.I.
# Sea Water	# Tank Cleaning	Mech. Seal	: Twin Seal SIC/SIC OR ANY RE
# Open sump /Pons	# Tunner/Flooded cellar	Rubber Part	Q.: Nitrile /Viton
# Fertilizer/ Coal Plant	# Waste Water/River	Hardware	: S.S.

NOTE :- We are also make this pump as per customer requirement & specification with variation fetures like pump with 60 Hz motor, Solid size, Material of Constuction like complete Stainless steel or any other material etc.