



**SPNC103M  
10 HP (7.5 Kw)**

4" (100mm) Hose  
(Flange / NPT / BSP - Optional)

**SUBMERSIBLE ELECTRICAL  
NON CLOG / SLURRY PUMP  
FOR ABRASIVE APPLICATION  
AND CORROSIVE APPLICATION**



**DESIGN ADVANTAGES**

- Options for Impeller MOC:
  - a) For abrasive and corrosion resistance application impeller are in ASTM A217 Gr. CA15 (SS 410)
  - b) For Sea water and corrosive application impeller available on request in ASTM A351 Gr. CF8M (SS 316)
- SS 304 Pump Volute, Hardware, Outlet and SS 431 Rotor Shaft.
- Tandem TC/TC mechanical seals enclosed in pressure compensated oil chamber.
- Thermal Cutouts are imbedded in motor winding for maximum protection.
- NBR lined wear plate for field adjustment.
- For saline environment Zinc Anode are available.
- Pumps are also available in complete SS 316 construction.
- Pumps are available for any combination of voltage and frequency on request.
- The Pump is epoxy coated for long life.



# SUBMERSIBLE ELECTRICAL NON CLOG / SLURRY PUMP

## TECHNICAL DETAILS

### MECHANICAL SEAL

Tandem TC/TC mechanical seals enclosed in pressure compensated oil chamber.

### BALL BEARINGS

Upper bearing : Single row, deep groove ball bearing.  
Lower bearing : Double row, angular contact bearing.

### POWER CABLE

Cable Size : 4 core 4.0 sq.mm  
Cable Length : 15 meters

PVC insulated, water and oil proof copper conductor flexible cable with cable support clamp assembly.

### STANDARD MOC

Impeller : S.S. CA15 , Nitride Hardened to 50-55 HRC  
Rotor Shaft : S.S. 431  
Wear Plate : NBR Lined  
Motor Body : Extruded Aluminum with Epoxy Powder Coating  
Pump Volute : S.S. CF8 (S.S. 304) with Epoxy Powder Coating.  
Hardware : S.S 304

### ELECTRICAL MOTOR (DOL - START)

2 Pole continuous rated induction motor with squirrel cage rotor.

Frequency (Hz) : 50  
AC Supply (Phase) : 3  
Voltage (V) : 415  
Power Rating (Kw) : 7.5  
Current Rating (FL) (Amp) : 16  
Speed (RPM) : 2850  
Motor Winding Insulation Class : H  
Max. temp. of pumped Fluid (°C) : 40  
Max. Start / Stop per hour : 15

### PUMP WEIGHT

Approx. without cable (Kg) : 70

### PUMP SUBMERGENCE

Pump submergence below Fluid level minimum 70 mm & maximum 15 meters.

### SOLID HANDLING CAPACITY : 60 mm

*(Optional items are at extra cost.)*

## SPNC103M 10 HP(7.5 Kw)

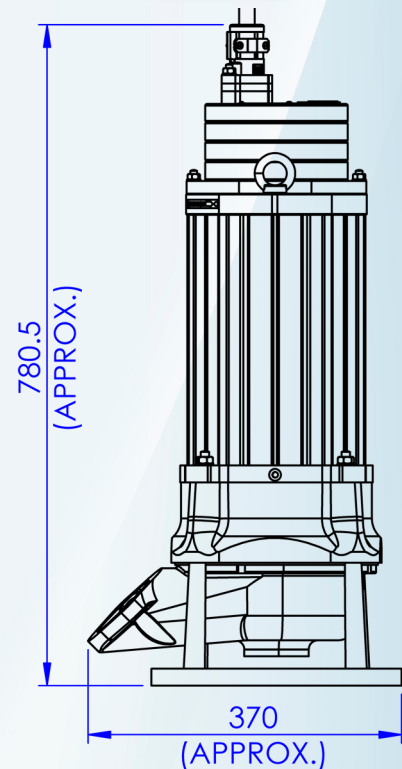

## PERFORMANCE CURVES

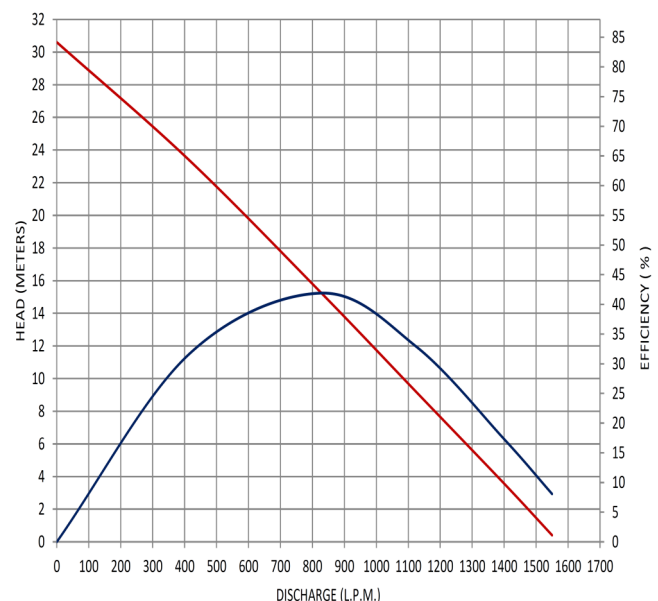



## Pioneering Innovative Advantages

### SPNC103M 10 HP(7.5 Kw)

**Protection of Motor :** Motor is a prime mover part of the pump so the protection is an utter most important. So, Thermal Cut-off Switch 50C Normally Closed are embedded in motor winding. Thermal switches a versatile and reliable thermal protector used to prevent overheating and ensure safety. This device is designed to interrupt the current flow when the temperature rises to a specified set point, effectively protecting the connected components or system from potential damage due to excessive heat. Motors are H class insulated (max temperature up to 180°C ).

**Motor Body :** Due to robust usage of pump and with minimum submergence at operation site, it is recommended to use aluminum extrusions alloy for best heat dissipation which allows it to run for a longer time as compared to cast iron pumps.

**Bearings :** Pumps are provided with Double row deep groove ball bearings are fitted on the rotor at the impeller side (DE) for maximum trust loads to be taken by the pump and the upper ball bearing (NDE) is a single ZZ bearing. All the ball bearings are filled with high temperature lithium grease containing special anti-corrosive additive which ensures long life during the life cycle of the pumps .

**Motor/Rotor shaft sealing :** Tandem double mechanical seals (TC vs TC) are used for leak proof sealing to protects the motor from muddy water, abrasive application thus ensuring long life.

As pumps are light weight and portable in operations.

**Cable protections :** Cable and its leads are sealed in such a way that water enter is far from impossible because it has cable grommets to seal the diameter of the cable and lead grommets to seal the individual leads wire which are subsequently connected to motor leads by wire nut connector and cover with heat shrink.

**Cable Arrester :** Which is fitted to the cable and protect the pump cable connections for any pulling of the cable. Arrester holds cable from coming out from the gland.

**Power cables :** Power cables are 100% water and oil proof available in any form PVC/EPR/HO7RNF depends upon the application where the pump is been used.

**Anodes :** For Sea water application pumps are fitted with sacrificial zinc anodes for better life of the Pump.

**High corrosion resistance :** For corrosion resistance all wet end parts such as hardware, strainer, outlet, lifting hooks and mechanical seals, seal housing are in stainless steel to avert corrosion.

**For abrasive application :** SS 410 Impellers are Nitride hardened (HRC 50 TO 55) also providing SS 316 & 27% high chrome impeller (optional) for better life in abrasive and muddy applications.

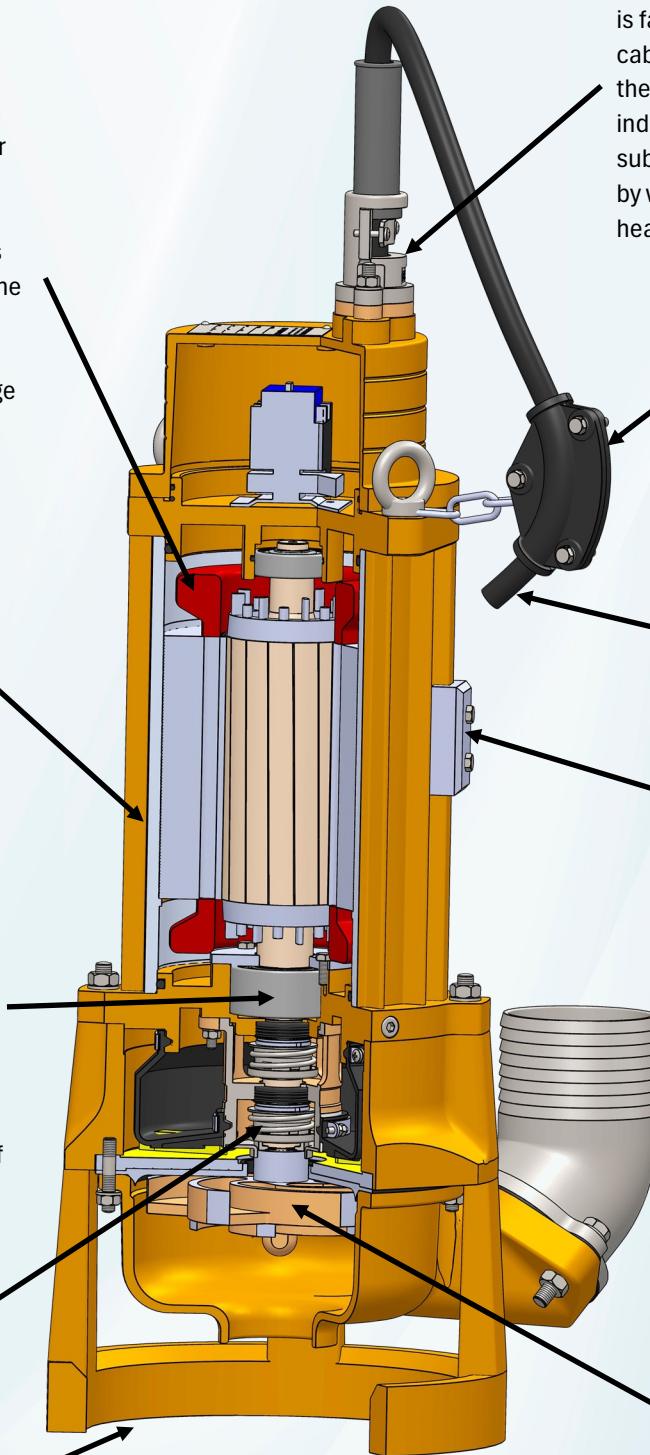



## PUMP CONTROL PANELS



**INDOOR PUMP CONTROL PANEL**

**OUTDOOR PUMP CONTROL PANEL**

**Durable trusted parts :**

All materials are used of reputed brands which are like contactors, relays, circuit breakers. Function / protection against low current, high current, overload and faulty connections.

**Rigid Body :** Control panels are all season proof and suitable for all site conditions.

**Indicators :** CONTROL PANEL indicators glow's when the pump starts with all the 3 phases connected to a LED light easily visible for identification that panel and pump are working.

**Safety Features :** We have installed advance device which protects in phase failure, dry run, overloading, Single phasing fault etc.

**Additional safety :** We use ELR which enables the pump to trip whenever there is current leaks it gets grounded. All wires are FRLS of reputed makes.

**User friendly operations :** Control panel where each wire connected has numbering and coding for easy understanding of the circuit diagram. Thus, a lay man can also connect a pump for operation. More over a copy of circuit diagram is fixed inside the panel.

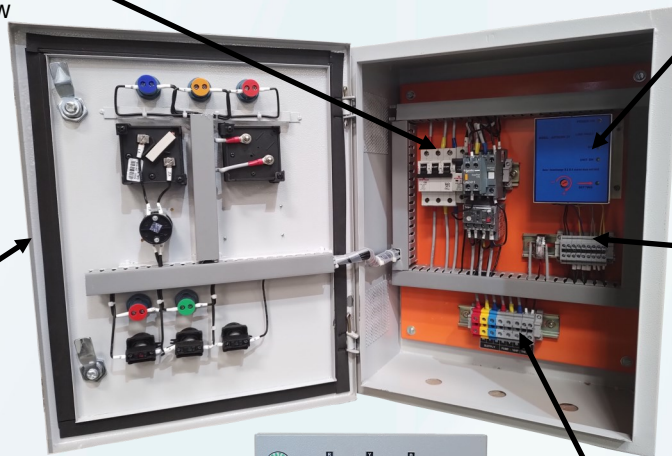

### KEY FEATURES

- \* DOL / STAR-DELTA CONNECTIONS
- \* PUMP DRY RUN PROTECTION
- \* PUMP SINGLE PHASING PROTECTION
- \* PUMP OVERLOAD PROTECTION
- \* PUMP UNDER LOAD PROTECTION
- \* THERMAL CUT-OFF PROTECTION
- \* OPERATING VOLTAGE & CURRENT DISPLAY
- \* IP54 INGRESS PROTECTION FOR INDOOR PANELS
- \* IP65 INGRESS PROTECTION FOR OUTDOOR PANELS
- \* AVAILABLE IN ANALOG & DIGITAL CONTROL SYSTEM